



Project _____

Item No. _____

Quantity _____

CT301 Countertop Electric Deck Oven



Model(s) Available

- CT301 - single compartment, two deck oven

Construction

- Stainless steel front, top and sides
- Aluminized steel back and bottom
- Safe door operation - stainless steel handles are raised 3.5" from the surface of the door
- 1.75" insulated doors - 15% thicker than the competition
- High-temperature mineral fiber sheet insulation on top, back, sides and bottom
- Aluminized steel baking compartment liner

Operation

- 3 tubular type heaters (208 or 240 VAC) 3750 total watts
- Thermostat actuated contactor heater control
- Easy to use, high efficiency controls with timer. Located on the side, our controls will not overheat.
- 3.75" (95mm) deck heights - more room between decks than the competition

Standard Features

- Temperature range of 150° to 550°F
- .625" thick Quick Heat Technology™ baking stones for crispy crusts
- Eighteen months parts and one year labor warranty
- 4" legs with adjustable sanitary feet
- Individual adjustable venting system per deck
- Fan cooled controls
- 6-20 NEMA cord and plug (*1 phase ovens only*)

Options & Accessories

- Deck cleaning brush (at additional charge)

SHORT FORM SPECIFICATIONS: Provide Marsal CT301 countertop electric deck oven. Unit shall have one door, with 1.75" thick insulation and a stainless steel handle raised 3.5" from the door surface. Oven insulation shall be 1" high-temperature mineral fiber sheet insulation on top, back, sides and bottom. Unit shall operate with 3 tubular type heaters with a thermostat actuated contactor heater control. High efficiency oven controls include one hour timer. Unit shall have two deck cooking surfaces, each shall be .625" thick Quick Heat Technology stone with 3.75" (95mm) space between decks. Provide with eighteen month oven parts and one year labor warranty. Provide with options and accessories as indicated

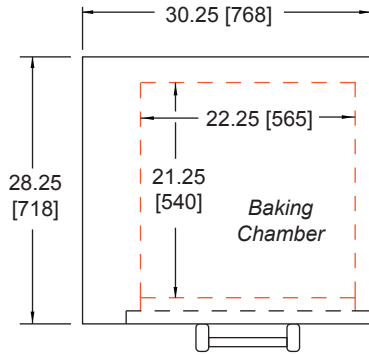

TOP VIEW

DIMENSIONS ARE IN INCHES [MM]

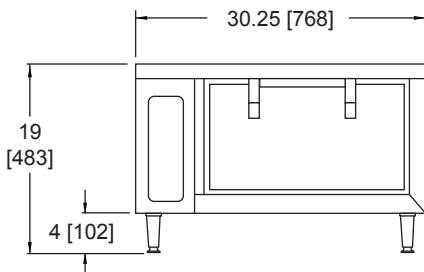

FRONT VIEW

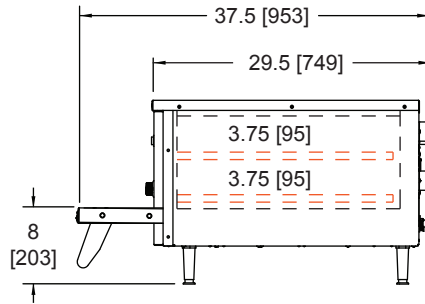

SIDE VIEW

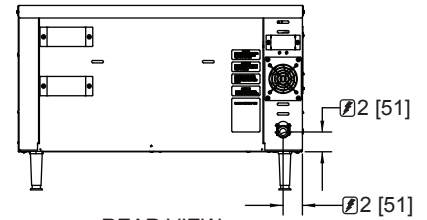

REAR VIEW

2" clearance required on sides and back

Specifications

Exterior Dimensions	30.25" W x 28.25" D x 19" H on legs (768 x 718 x 483 mm)
Cooking Deck Dimensions	21" W x 21" D x .625" H (533 x 533 x 16 mm)
Number of Doors	1
Number of Cooking Decks	2
Height Between Decks	3.75" (95mm)
Shipping Weight	232 lbs (105 kg)

Electrical Specifications

Voltage	Phase	Amperage	Power (KW)
208	1*	18	3.75
	3	11	
220	1*	17	3.75
	3	10	
240	1*	16	3.75
	3	9	

* 1 phase ovens ship with electrical chords

Copyright 2017 Marsal . All designs and specifications presented in this document are subject to change without notice due to constant innovation.