

HERITAGE

PROFESSIONAL USE

Ideal for Parma ham and the finest salami of the best gastronomic tradition, realized to enhance their most excellent properties.

Easy to use, thanks to the smoothness of the flywheel and to the mechanical feed of the product holder.

Easy operation and cleaning, in complete safety.

Made in Italy.

Omas has assured quality, innovation, safety and design for over sixty years.

OMAS

Food technology solutions

VAN BERKEL USA, INC.

5675 NW 84TH AVENUE
DORAL, FL 33166
USA

OFFICE + 1(786)409-7052

VBUSA@BERKELINTERNATIONAL.COM

WWW.OMAS1949.COM



The **OMAS** vertical fly-wheel slicer **HERITAGE** is the main slicer of the delicatessen owner belonging to a great tradition, with all the advantages and ease combined with the charming aesthetic impact of a modern working instrument with a contemporary design. It is the synthesis of tradition and innovation, the two fundamental values of OMAS.

The stylish line the OMAS red flywheel slicer is the result of the transformation of the traditional flywheel slicer designed in the OMAS factories during the 50's into a new modern slicer that gives the taste of the past, enabling the operator to do this job with the manual sensitivity tradition taught him and the advantages of the modernity, assuring high performance of the professional user with maximum safety thanks to the protections prescribed for professional use machines.

FLY WHEEL

HERITAGE

PROFESSIONAL USE

Ideal for Parma ham

- the product holder is large enough to take a whole ham
- the precise slice-thickness knob (0 - 1/16") assures very thin slices, for the enjoyment of the taste of your special products and to obtain the most, in terms of quality and quantity, from the best hams and salami
- tempered and chromium-plated blade, 12 1/2" inches diameter, to guarantee a perfect cut without waste, essential if you are processing fine products
- the pusher prevents the displacement of the product on the plate, so that all slices are perfectly cut.

Easy to use

- the smoothness of the carriage movement and of the flywheel rotation make the work for the operator really light
- the mechanical feed of the product holder for a set slice-thickness guarantees a constant and always perfect cut because the thickness is not altered by the pressure normally applied on the blade by the operator or by the product itself
- the slicer is fully manual and does not need any power supply. This allows to reproduce the old fashioned movements of the delicatessen operator and to use the slicer even in situations where a wire would spoil the elegance of the location, as for example in the middle of a beautiful dining room
- the front support feet can be adjusted in 2 different positions, according to the dimensions (depth) of the working surface

Easy operation and cleaning, in complete safety

- easy operation is always our first target and every part of the machine in contact with food is easily removable: slice deflector, product holder
- the built-in sharpener guarantees a perfect and constant grinding and honing, running automatically it makes the sharpening operation easy
- the blade protection ring assures a safe use of the slicer. The machine is also equipped with a front safety protector to cover the sharp edge of the blade when the slicer is not being used



An elegant, strong base made especially for flywheel slicer is available.

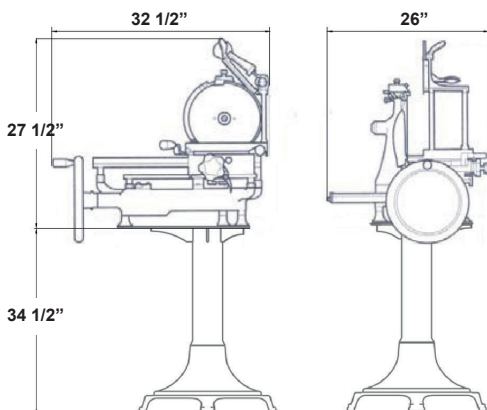

Blade inches

12 1/2"

Drive

Chain

Cut thickness

0 - 1/16" inches

Slicing capacity inches

□ 11"x8 1/2"

○ 8 1/2"

Pounds

117 lbs